



# **Solidcom BPK01 Beltpack**

## **Quick Guide**

V1.0

**EN** Please read this Quick Guide carefully. We wish you a pleasant experience. To obtain Quick Guide information in other languages, please scan the QR code below.



## ■ Safety Instructions

For safety purposes, please read the following safety precautions before using the device to ensure proper product usage:

- Do not install the device near or inside heating appliances, cooking equipment, high-pressure containers (such as microwaves, induction cookers, electric ovens, electric heaters, pressure cookers, water heaters, gas stoves, etc.) to prevent battery overheating and explosion.
- Use only original manufacturer-certified chargers, cables, and batteries. Unauthorized or incompatible accessories may cause electric shock, fire, explosion, or other hazards.
- Prevent the power cord from being stepped on or squeezed, especially at the plugs, sockets, and extended sections.
- Disconnect the power plug during thunderstorms or when the device is not in use for extended periods.
- Do not disassemble the device unless directed by qualified manufacturer technicians.
- All repairs must be performed by authorized service personnel.

## Key Features

- The central station and antenna module feature a modular design. The central station supports cascading up to 8 antennas, while each antenna can operate independently without the central station. In standalone mode, antennas allow cascading of up to 3 units. Each antenna accommodates connections with 20 belt packs, enabling flexible network configurations to achieve full-duplex communication for 10–80 belt packs.
- The antenna delivers a 500-meter wireless coverage radius, with 8 antennas cascaded covering an area larger than 900 football fields. Seamless roaming cascade between antennas ensures uninterrupted connectivity, allowing belt packs to move freely within the coverage zone without signal dropout.
- The belt pack features four dedicated call buttons and one reply button. Each call button supports binding with up to 4 audio channels. A single belt pack can support full-duplex communication with up to 16 audio sources simultaneously.
- The system supports storage of up to 100 group configurations, 100 role presets, and 80 belt pack profiles, enabling customized communication logic for diverse client scenarios while eliminating repetitive system configuration tasks.
- Ultra-compact belt pack (net weight: 305g) with integrated Bluetooth 5.2 module. Compatible with mainstream wireless headsets, enabling cable-free operation on set.
- Auto-Cascade enables plug-and-play connectivity between Geo Central Station and Solidcom ANT01 Antenna via Ethernet, requiring zero IP configuration or manual network parameter setup.
- The belt pack features fast pairing via the charging base. By cascading the charging base into the central station/antenna network, automatic pairing and one-click system configuration deployment can be achieved, significantly improving the efficiency of configuring large-scale systems.
- The Geo Central Station/Solidcom ANT01 Antenna supports WiFi/Bluetooth connectivity with PCs and mobile devices. Wireless access via web configuration interface and dedicated APP enables remote adjustment of system parameters.

## Key Features

- The system configuration document supports local import and upload, as well as cloud-based virtual configuration. This enables remote system configuration design, which can be saved locally for later on-site upload, significantly improving workflow efficiency.
- The central station features a built-in 4×4 DANTE port, enabling direct integration of the intercom system into the on-site DANTE/AES67 network.
- The intercom system enables remote configuration access via web interface, allowing technical support personnel to provide real-time assistance over internet connections for on-site issue resolution.
- Systems equipped with the Geo Central Station support remote access for up to 8 cloud-based APP users, while systems solely equipped with the Solidcom ANT01 Antenna still support remote access for up to 4 cloud-based APP users. Real-time global access from any location is achievable via the internet.
- The beltpack (IP65-rated) and antenna (IP54-rated) provide water and dust resistance, enabling reliable operation in rain or adverse weather conditions.
- The beltpack system features replaceable batteries and includes a standard charging base capable of simultaneously charging 10 beltpacks or 10 individual batteries, with each battery providing 15+ hours of continuous operation.
- The professional intercom headset features a 0B10 interface, combining rugged durability with ergonomic comfort. Equipped with Dual-Mic ENC (Environmental Noise Cancellation), it delivers high-quality audio communication in noisy environments.

\* The related data is based on Hollyland laboratory test results.

# Product Overview

## Product Interfaces

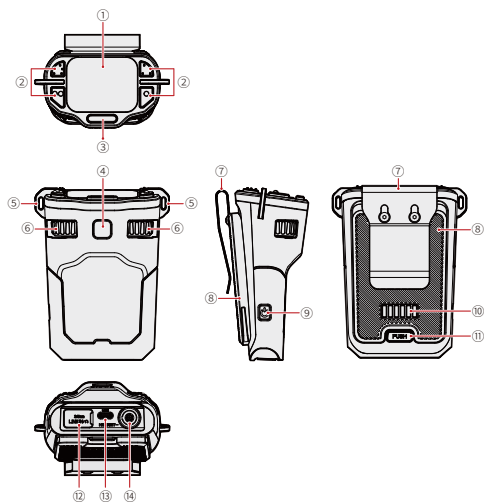

1. Display Screen
2. Call Buttons (A/B/C/D)
3. Reply Button (for call response)
4. Menu Button
5. Metal Component (lanyard eyelet / impact-resistant design)
6. Volume Knob
7. Metal Clip
8. Removable Battery
9. Power Switch
10. Charging Contacts (6-pin)
11. Battery Eject Button
12. 3.5mm Jack (LINE IN/headset)
13. USB-C Port (for charging/device pairing/upgrade)
14. 10-Pin LEMO Interface (for headset / accessories connection)

## Product Interfaces

### 10-Pin LEMO Interface

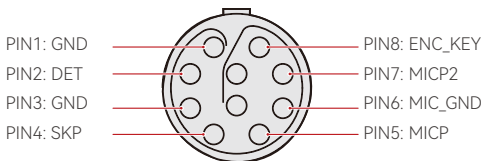

### 3.5mm Jack

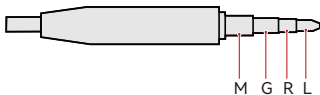

Interface Definition: M G R L

Microphone Capsule Impedance: 600 $\Omega$

Speaker Impedance: 32 $\Omega$

## Home Page Introduction

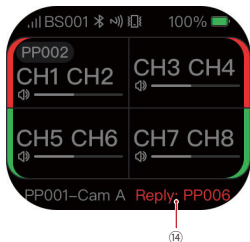
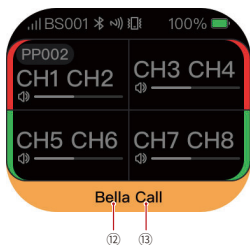
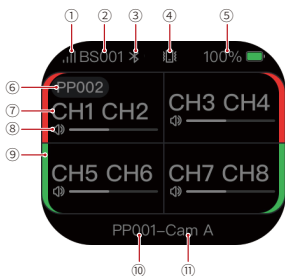

1. Signal Strength
2. Connected Antenna Name
3. Bluetooth Status (white: on, gray: off)
4. Vibration Status (white: on, gray: off)
5. Battery Level
6. Call Target
7. Communication Target
8. Output Gain for Communication Target
9. Talk Permission for Communication Target
10. Beltpack Name (displays beltpack ID if unnamed)
11. Assigned Role Group of Beltpack
12. Incoming Caller Name
13. Channel Used by Caller
14. Missed/Unanswered Caller

## Product Pairing

### ■ Charging Base Pairing

This product supports automatic pairing with the antenna via the charging base:

1. Ensure that both the antenna and the charging base are powered on and functioning normally. Use a standard RJ45 Ethernet cable to connect the antenna to the charging base. Once successfully cascaded, the front indicator light of the charging base will turn solid blue.

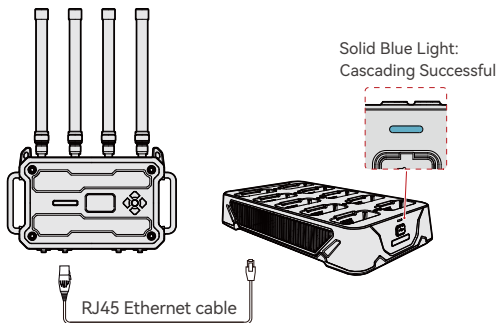

2. Insert the beltpack vertically into the cascaded charging base. After approximately 3 seconds, the beltpack will automatically pair with the current cascaded system.

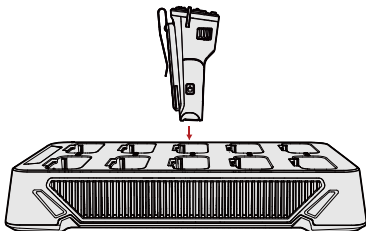

## Specifications

Solidcom BPK01 Beltpack	
Model	Solidcom BPK01
Product Name	Full-Duplex Wireless Intercom System
LOS Range	500m
Operating Frequency	DECT: 1880~1930 MHZ; BT: 2402~2480 MHZ
Transmit Power	DECT: 24 dBm; BT: 3 dBm
Bandwidth	1.728 MHZ
Modulation Mode	GFSK
Receiver Sensitivity	-90 dBm
Battery Life	>15h
Dimensions	114.65mm × 89.2mm × 61.8mm
Weight	305g
Ingress Protection (IP) Rating	IP65
Operating Temperature	-10~45°C
Storage Temperature	-20~60°C
LEMO Audio	
Input Frequency Response	200HZ~6.5 KHZ
Maximum Input SPL	120 dB SPL
Noise Cancellation Depth	20dB
Distortion	<1%
Signal-to-noise Ratio (SNR)	67dB
Output SPL Level	113 dB SPL max

## Safety Precautions

Do not place the device near or inside heating devices (including but not limited to microwave ovens, induction cookers, electric ovens, electric heaters, pressure cookers, water heaters, and gas stoves) to prevent the battery from overheating and exploding. Use the original charger, data cables, and batteries provided with the product. Using unauthorized or incompatible chargers, data cables, or batteries may cause electric shock, fire, explosion, or other dangers.

## Support

If you encounter any problems in using the product or need any help, please contact Hollyland Support Team via the following ways:

-  Hollyland User Group
-  HollylandTech
-  HollylandTech
-  HollylandTech
-  support@hollyland.com
-  www.hollyland.com

## Statement:

All copyrights belong to Shenzhen Hollyland Technology Co., Ltd. Without the written approval of Shenzhen Hollyland Technology Co., Ltd., no organization or individual may copy or reproduce part or all of any written or illustrative content and disseminate it in any form.

## Trademark Statement:

All the trademarks are owned by Shenzhen Hollyland Technology Co., Ltd.

## Note:

Due to product version upgrades or other reasons, this Quick Guide will be updated from time to time. Unless otherwise agreed, this document is provided as a guide for use only. All representations, information, and recommendations in this document do not constitute warranties of any kind, express, or implied.

# **HOLLYVIEW**

Powered by Hollyland

---

Shenzhen Hollyland Technology Co., Ltd.

8F, 5D Building, Skyworth Innovation Valley, Tangtou Road, Shiyan Street, Baoan District,  
Shenzhen, 518055, China

MADE IN CHINA